

The 4G LTE eNodeB decides to add the 5G-NR base station as a secondary node. The eNodeB sends a Secondary Node Addition Request to the gNodeB. The message carries the RRC and Radio Bearer configuration. UE capabilities and security information are also included in the message.

The network indicates whether the UE shall use either KeNB (master node key) or S-KgNB (secondary node key) for the 5G DRB.

Allocate the 5G radio resources needed for the secondary session.

The gNodeB responds with information about the radio resources and bearers admitted with the 5G network.

The 4G eNodeB informs the secondary node (gNodeB) about the reconfiguration complete.

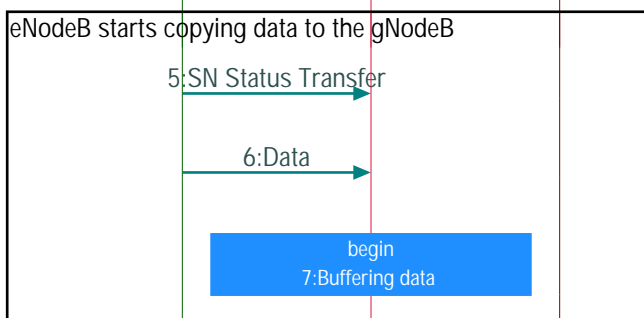

eNodeB informs the gNodeB about the PDCP SN and HFN for all the bearers that are being transferred to 5G.

SGW is sending data to the MN-eNB. The MN-eNB keeps forwarding that data to the SN-gNB.

At this point, the gNodeB is buffering the data as the UE has not established the 5G path.

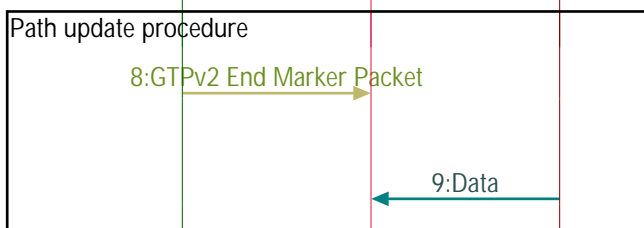

Send the End Marker to the eNodeB. This marks the end of data transmission to the 4G-eNodeB. Subsequent data transmissions will be towards the 5G-gNodeB.

Data is now being sent directly to the 5G-gNodeB.

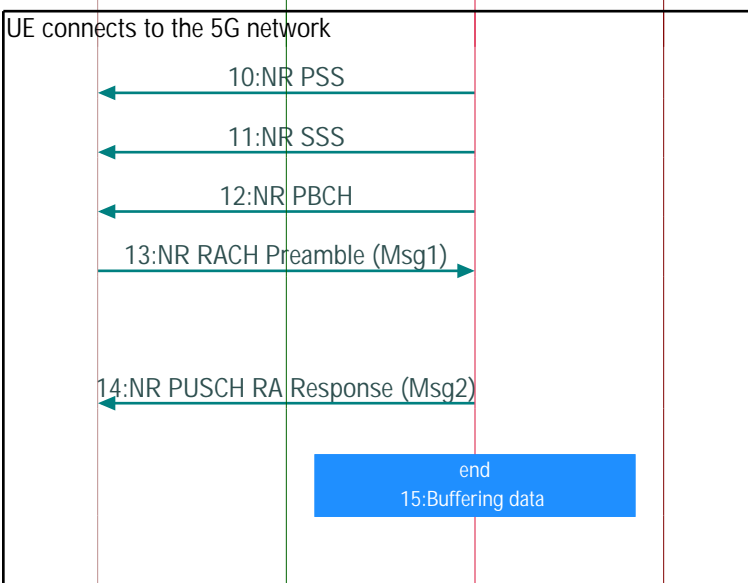

UE acquires the 5G-NR Primary Synchronization Signal.

UE acquires the 5G-NR Secondary Synchronization Signal.

UE acquires the 5G-NR Broadcast Channel.

The UE initiates the random-access procedure with the 5G gNodeB. Non-contention based random-access will be attempted if the preamble assignment was received in the RRC Connection Reconfiguration message.

The 5G secondary node gNodeB responds with an RA Response. The message also carries an uplink grant for Msg3 transmission.

The gNodeB stops buffering data and starts data transmission.

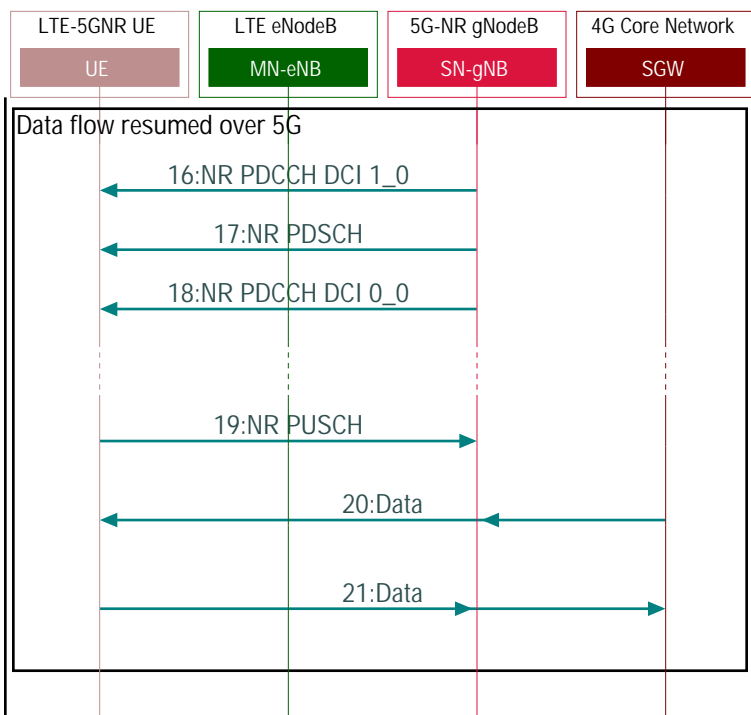

NR PDCCH signals downlink resource block allocations for PDSCH

The eNodeB transmits the PDSCH.

gNodeB assigns uplink resource blocks.

The UE receives the DCI 0_0 grant and transmits the PUSCH in the uplink direction.

Data is now being directly routed from the 4G SGW to the 5G gNodeB.

Uplink data is being transported from the 5G gNodeB to the 4G SGW.