

DHCP - Dynamic Host Configuration Protocol (Normal Operation)						
Subnet 1			Intranet	Subnet 2	Subnet 3	EventHelix.com/EventStudio 2.0
PC	Laptop 1	Server 1	Router	Server 2	Laptop 3	
PC	DHCP Client 1	DHCP Server 1	BOOTP Relay Agent	DHCP Server 2	DHCP Client 3	04-Jul-03 15:07 (Page 1)

Dynamic Host Configuration Protocol (DHCP) is used to dynamically provide IP addresses and configuration information to client nodes. DHCP provides greater flexibility by leasing out IP addresses to host nodes. DHCP supports mechanisms that can be used by hosts to renew their lease.

This sequence diagram describes the DHCP interactions between a Laptop and the DHCP servers in the intranet. Four different cases are covered.

- (1.) Laptop boots up for the first time and requests an IP address.
- (2.) Laptop's IP address lease is renewed.
- (3.) Laptop reboots and confirms IP address setting
- (4.) Laptop is disconnected and connected at a different place in the Intranet.

Copyright © 2000-2003 EventHelix.com Inc. All Rights Reserved.

(1.) Laptop boots up for the first time and requests an IP address

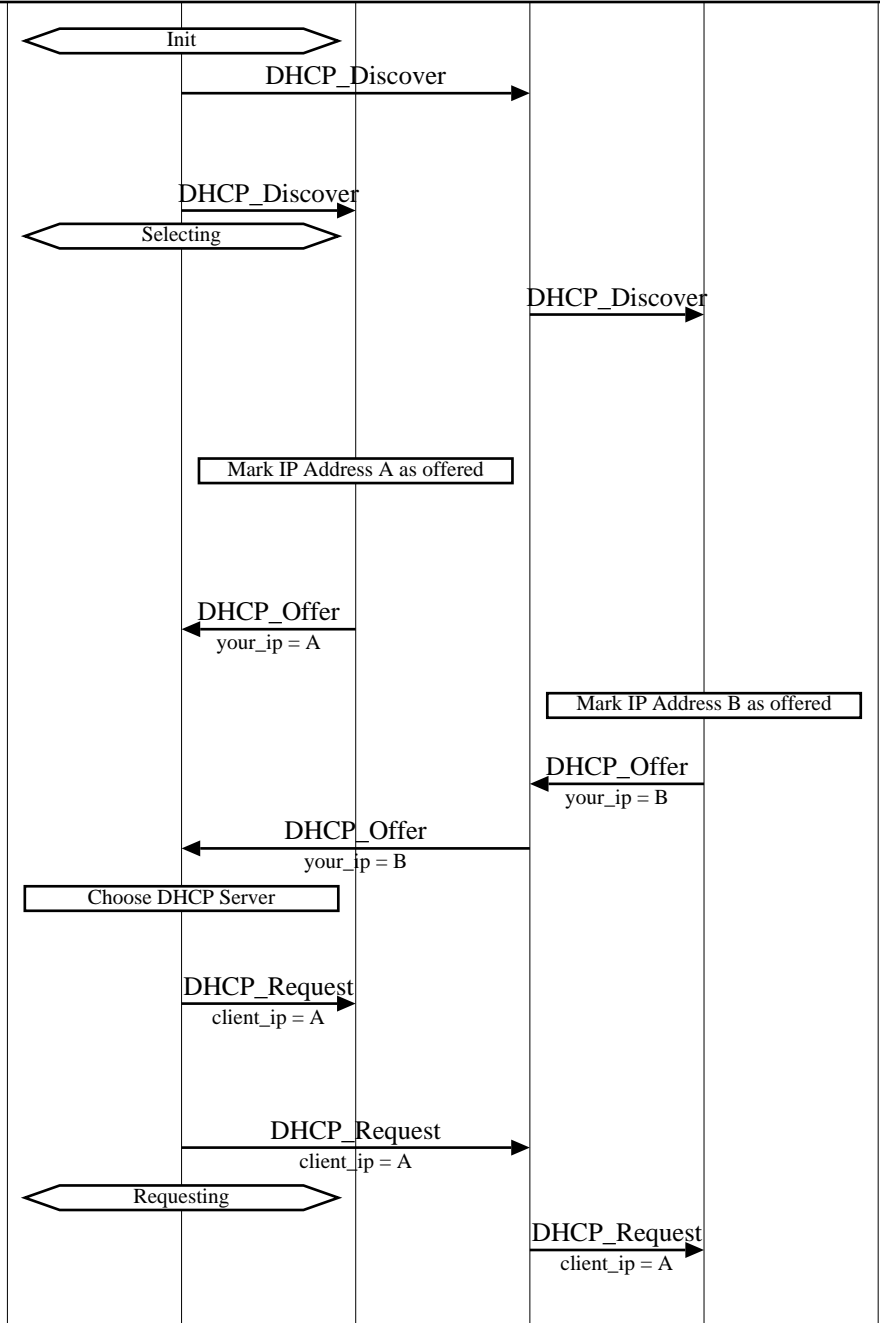

DHCP Client starts in the Init state

Client machine comes up without an IP address. It sends out a DHCP Discover message on its subnet to identify the DHCP Servers on the subnet.

Now the DHCP Client is in the selecting state

The message is picked up by the router and forwarded to a preconfigured DHCP Server on a different subnet. This functionality utilizes the BOOTP Relay Agent support in Routers. (See the BOOTP Sequence Diagram for details)

DHCP Server 1 selects IP address A and marks it as offered. (This prevents the same IP address from being offered to another client, before DHCP Client 1 has a chance to respond.)

DHCP Server on the same subnet responds with DHCP Offer and offers an IP address in the your IP address field

DHCP Server 2 selects IP address B and marks it as offered.

DHCP Client has received offers with IP address A and B. It selects one of the IP address

DHCP Client sends out a DHCP Request as a subnet broadcast. The selected IP address is stored in the client ip address field. In this case IP address A from DHCP Server 1 is selected

DHCP - Dynamic Host Configuration Protocol (Normal Operation)						
Subnet 1			Intranet	Subnet 2	Subnet 3	EventHelix.com/EventStudio 2.0
PC	Laptop 1	Server 1	Router	Server 2	Laptop 3	
PC	DHCP Client 1	DHCP Server 1	BOOTP Relay Agent	DHCP Server 2	DHCP Client 3	04-Jul-03 15:07 (Page 2)

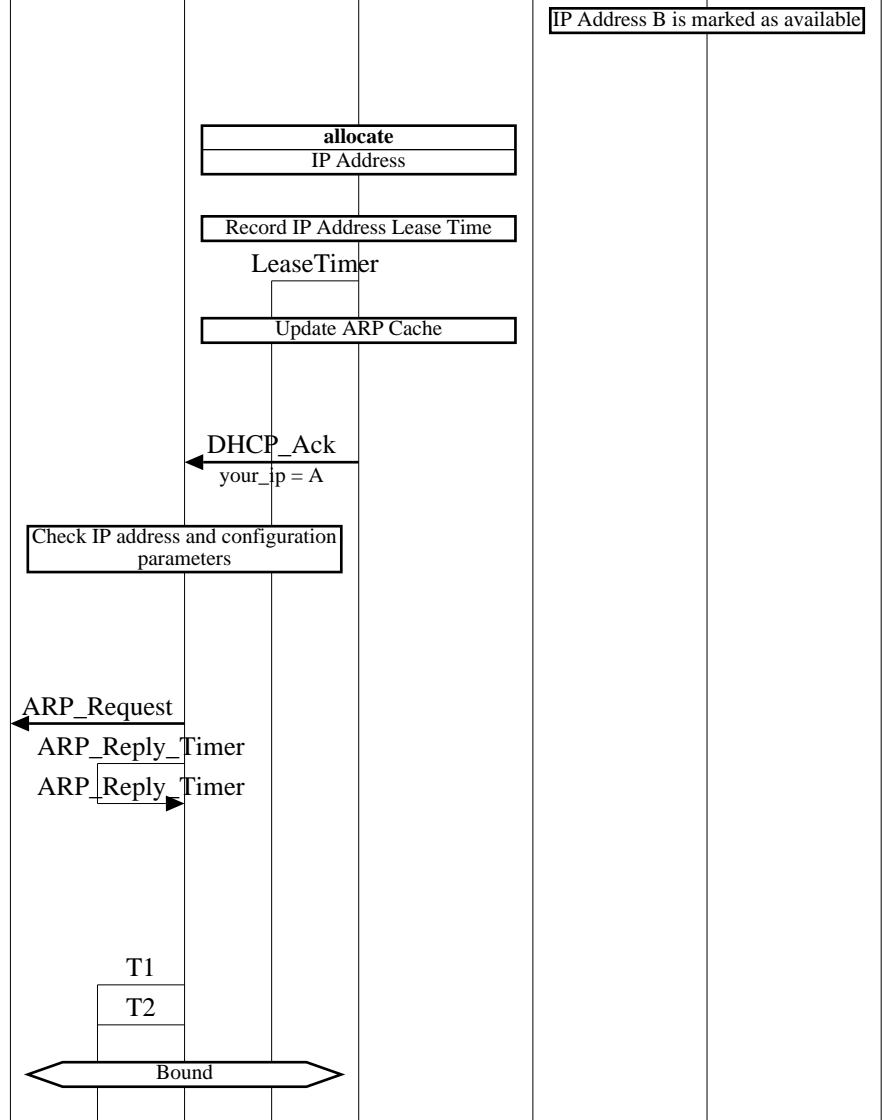

DHCP Server 2 sees that the client has sent a DHCP Request but it has not selected the IP address it had offered, so IP address B is returned to the free pool

DHCP Server 1 allocates IP address A and stores this binding on the disk along with the lease time.

A timer is started for the duration of the lease for the IP address

DHCP Server 1 responds by a unicast. This requires that the ARP Cache is updated with the hardware address for the device. (This functionality is similar to BOOTP)

After DHCP Ack is received, the client validates the information provided by the DHCP server.

Client verifies that the IP address assigned to it is unique. This can be accomplished by sending out an ARP Request for the assigned IP address. If no node responds to the ARP request, the client can be sure that the IP address is unique.

Timeout for a ARP Reply signals that the IP address is unique

IP address given by the DHCP server is a leased address for a given period (usually 3 days). Timer T1 and T2 are used to manage the address leasing.

Client starts T1 (typically 0.5 Lease Time)

Client starts T2 (typically 0.875 Lease Time)

DHCP address is now in use on this machine. This state is referred to as Bound

(2.) Laptop's IP address lease is renewed.

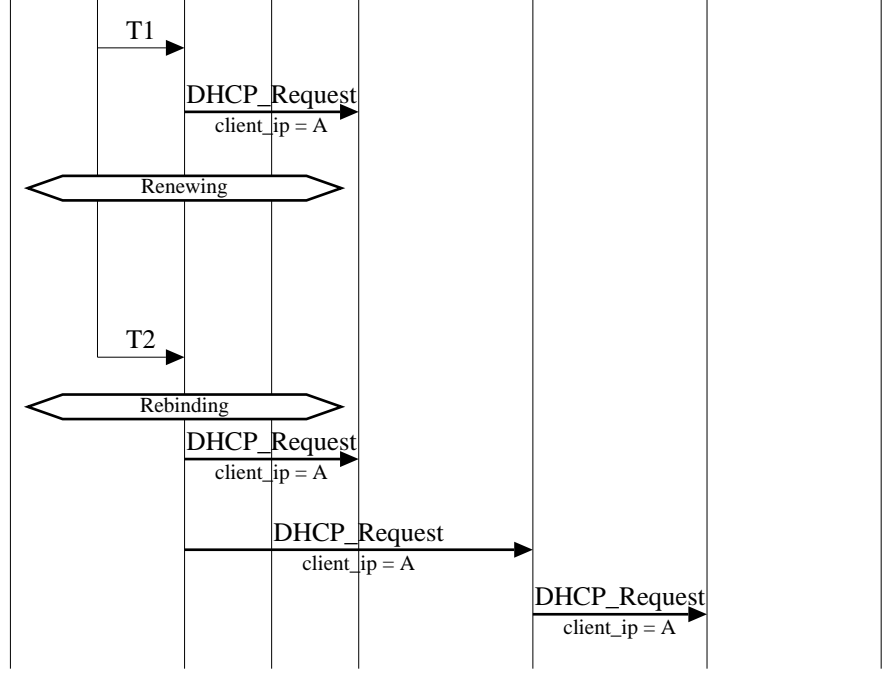

T1 has expired. Its time to renew the IP address lease

A unicast DHCP Request is sent to the DHCP Server which had assigned the IP address

DHCP client changes state to Renewing

At this point, the DHCP Server would respond with DHCP Ack. In this scenario we assume that the DHCP Server does not respond to the renewal request.

T2 times out but DHCP Ack has not been received from the DHCP Server

The client now enters the Rebinding state

DHCP Request is now broadcast on the subnet. Any DHCP server can respond to the request.

DHCP - Dynamic Host Configuration Protocol (Normal Operation)						
Subnet 1		Intranet	Subnet 2	Subnet 3	EventHelix.com/EventStudio 2.0	
PC	Laptop 1	Server 1	Router	Server 2		Laptop 3
PC	DHCP Client 1	DHCP Server 1	BOOTP Relay Agent	DHCP Server 2	DHCP Client 3	04-Jul-03 15:07 (Page 3)

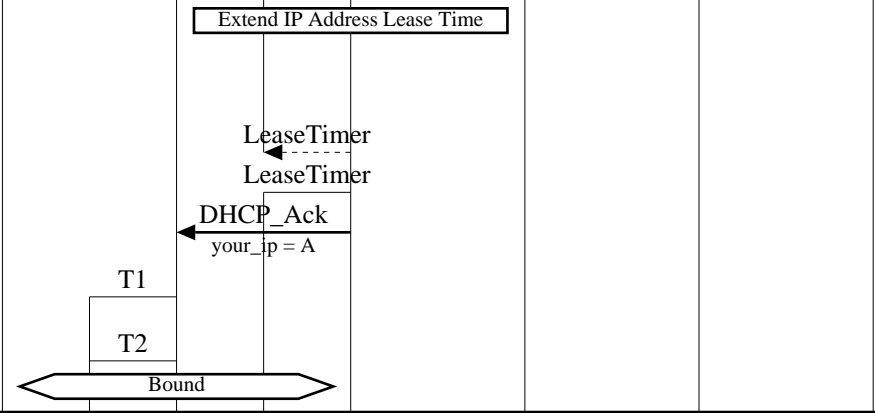

This time DHCP Server 1 receives the request. It extends the lease timer and starts a new timer corresponding to the lease time.

New lease timer is started
 DHCP Server sends the ack back to the client
 Client starts T1 and T2 corresponding to the new lease time

Now Client is bound

(3.) Laptop reboots and confirms IP address setting

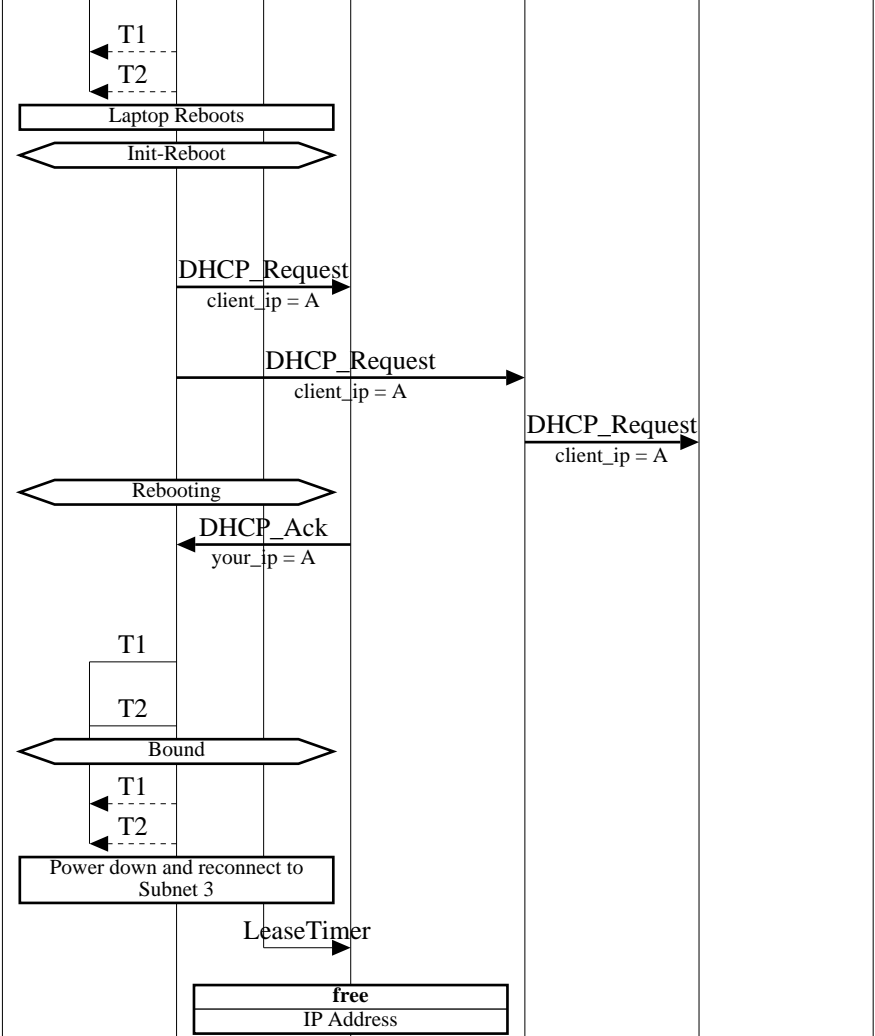

Client does have a configured IP address, so it enters the Init-Reboot state to confirm the IP address and other configuration information

Client sends a DHCP Request to confirm its IP address and configuration. This message is sent as a subnet broadcast.

DHCP Server 1 has leased out an IP address to the client and the lease is still active so it responds back with a DHCP Ack.

The client proceeds to Bound state after starting T1 and T2

The laptop is disconnected and reconnected at a different location
 DHCP Server 1 lease time for IP address A has expired

(4.) Laptop is disconnected from Subnet 1 and reconnected in Subnet 3

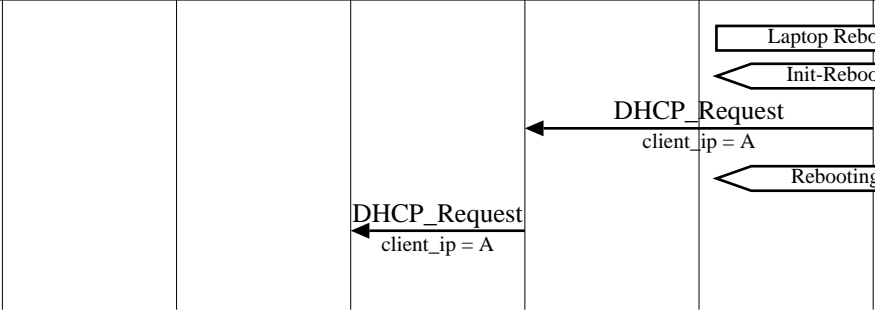

Laptop Reboots
 Init-Reboot
 Rebooting

DHCP - Dynamic Host Configuration Protocol (Normal Operation)						
Subnet 1			Intranet	Subnet 2	Subnet 3	EventHelix.com/EventStudio 2.0
PC	Laptop 1	Server 1	Router	Server 2	Laptop 3	
PC	DHCP Client 1	DHCP Server 1	BOOTP Relay Agent	DHCP Server 2	DHCP Client 3	04-Jul-03 15:07 (Page 4)

